

LPG Association Inc  
PO Box 1776  
Wellington  
New Zealand

[www.lpga.co.nz](http://www.lpga.co.nz)

**Code of Practice for  
LPG Compliance  
100kg to 300kg**

A code of practice for the ongoing 'compliance-validation'  
for 100kg to 300kg of LPG at a location  
(in storage or connected for use)

**Approved Code of Practice  
Under the Hazardous Substances and New  
Organisms (HSNO) Act 1996**

<b>Code of Practice:</b>	<b>HSNOCOP 50</b>
<b>Version:</b>	<b>1.0</b>
<b>Date of Approval:</b>	<b>June 2011</b>

## Approval of Code of Practice

This code of practice HSNOCOP 50 Version 1.0 is approved pursuant to sections 78 and 79 of the Hazardous Substance and New Organisms Act 1996 (**HSNO Act**). The Environmental Risk Management Authority (**the Authority**) has delegated the power to approve codes of practice to the Chief Executive of the Authority, and this Code is approved in accordance with that delegation. It is confirmed that the requirements of sections 78 and 79 have been met. Approval of this code is limited to matters that relate to the HSNO Act and the regulations made under that Act.

In its decision on application HRE09001 to seek a modified reassessment of LPG, propane, butane and isobutene (the substances), the Authority decided in accordance with section 77A(1) of the HSNO Act that the following control may be imposed:

Despite regulation 81 of the Hazardous Substances (Classes 1 to 5 Controls) Regulations 2001, a person in charge of a hazardous substance location where less than 300 kg of the substances are present does not require a current location test certificate if:

- a. The location has been granted a previous location test certificate in respect of the substances; and
- b. The location has passed a compliance check in accordance with a code of practice approved by the Authority under section 78(10) of the Act.

This Code has been developed by the LPG Association of New Zealand Inc to enable compliance checking of such hazardous substance locations.

Notice of approval of this Code is intended to be published in the New Zealand Gazette dated 30<sup>th</sup> June 2011.

Pursuant to section 80(1)(a) of the HSNO Act, this Code may be inspected on request at the Wellington office of ERMA New Zealand BP House, 20 Customhouse Quay, Wellington. Pursuant to section 80(1)(b) of the Act, the Code can be obtained from the LPG Association Inc, PO Box 1776, Wellington, 6140; website: [www.lpga.co.nz](http://www.lpga.co.nz); email [info@lpga.co.nz](mailto:info@lpga.co.nz)

Approved this 25<sup>th</sup> day of June 2011.

A handwritten signature in black ink, appearing to read 'Rob Forlong', is written over a faint, light grey watermark that says 'ERMA New Zealand'.

Rob Forlong  
Chief Executive  
ERMA New Zealand

# Contents

- 1. Purpose ..... 4
- 2. Limitation of CoP ..... 5
- 3. Definitions ..... 6
- 4. Procedures for LPG Delivery ..... 7
- 5. Renewal of CoP Compliance Plaque ..... 8

Appendix A  
LPG Location Compliance Guide for Trained LPG Delivery Operator

Appendix B  
LPG Cylinder Location 'Compliance-Validation'

# 1. Purpose

The purpose of this Approved Code of Practice is to provide for the ongoing compliance checking and validation of LPG facilities where cylinders with a total quantity between 100kg and 300kg of LPG are present at a hazardous substance location either in storage or connected for use. This code applies:

- in respect of Regulation 81 of the Hazardous Substances (Classes 1 to 5 Controls) Regulations 2001 [as varied by HRE09001 Decision for LPG, propane, butane and isobutane]; and
- subsequent to the hazardous substance location having a valid location test certificate<sup>1</sup> issued by a test certifier; and
- where LPG cylinders are supplied or filled in-situ by a trained LPG Delivery Operator.

This code of practice “LPG Compliance 100kg to 300kg” (hereinafter CoP) is approved by ERMA New Zealand under the Hazardous Substances and New Organisms (HSNO) Act 1996 as a means of compliance with the Hazardous Substances (Classes 1 to 5 Controls) Regulations 2001, as varied for LPG, propane, butane and isobutane in accordance with the Environmental Risk Management Authority Decision HRE09001<sup>2</sup>

This CoP provides a practical means to manage regulatory compliance with the aim of protecting the environment and the health and safety of people and communities by preventing or managing the adverse effects of LPG.

---

<sup>1</sup> Hazardous Substances (Classes 1 to 5 Controls) Regulations 2001 regulation 81

<sup>2</sup> Refer [www.ermanz@govt.nz](http://www.ermanz@govt.nz) for details

## 2. Limitation of Code of Practice

This CoP provides a mechanism for ongoing compliance checking and validation of the controls required for LPG at a hazardous substance location where:

- the LPG is stored in cylinders, and
- The cylinders are located outside, and
- The total quantity of LPG is greater than 100 kg and less than 300 kg.

If the location is changed, the hazardous substance location must be re-issued with a valid location test certificate by an approved test certifier, before the items required by this CoP can be applied.

A change to the location includes those items specified in Appendix A (iii).

This code is only applicable when the site does not require an approved handler, that is, when the LPG cylinders are secured. In this context, secure means that the only actions, apart from use of the LPG, are undertaken by the Trained LPG Delivery Operator. Persons on site must not connect the cylinders, disconnect the cylinders, or take actions which release LPG.

This CoP does not detail the requirements of other legislation. Compliance with this CoP does not obviate the requirement to comply with other sections of the HSNO legislation (or related regulations) or other legislation such as the Health and Safety in Employment Act 1992, the Gas Act 1992 or the Resource Management Act 1991.

### 3. Definitions

#### LPG Supplier

The LPG Supplier is the business that provides LPG to the LPG hazardous substance location for reward. The LPG supplier is accountable for ensuring compliance with this CoP. The LPG supplier shall maintain full records of training and competence of Authorized Signatories & Trained LPG Delivery Operators implementing this CoP that will be available for auditing by ERMA New Zealand.

#### Authorised Signatory

The Authorised Signatory is a person appointed by the LPG Supplier who is responsible for ensuring compliance with this CoP by the LPG supplier. Authorised Signatories shall:

- have received training and shall have demonstrated competence regarding the application and the responsibilities required by this CoP at least every 5 years; and
- where they are satisfied on reasonable grounds that the requirements have been met, sign the 'LPG Cylinder Location Compliance-Validation' (Appendix B).

#### Trained LPG Delivery Operator

The Trained LPG Delivery Operator is a person who delivers and connects exchange LPG cylinders and in-situ fill LPG cylinders. The Trained LPG Delivery Operator shall:

- have received training and demonstrated competence to the LPG supplier with respect to their responsibilities for applying this CoP at least every 5 years; and
- for in-situ fill only, holds a current Approved Handler and Approved Filler Test Certificates issued by a Test Certifier registered for this activity.

#### Compliance Plaque

Compliance Plaques are non-removable<sup>3</sup> plaques that have the following form:

<b>HSNOCOP 50</b> <b>LPG 100kg to 300kg Compliance-Validation</b>  <b>Unique Plaque No:</b> (See Note 1).....  <b>Expiry Date:</b> (dd/mm/yy).....  <b>Expiry Date:</b> .....  <b>Expiry Date:</b> .....
---

Note 1 The unique plaque number has a prefix indicating the company name followed by a 5 digit unique number, e.g. NE-00076. Company prefixes are allocated by the LPG Association Inc. Examples include:

Contact Energy	CE
Elgas	EG
Nova Gas	NE
On Gas	OG

<sup>3</sup> In this context, non-removable means unable to be removed without being damaged and rendered unusable.

## **4. Procedures for LPG Delivery**

### **4.1 Prior to first LPG Delivery under the provisions of this CoP**

Prior to the first delivery of LPG under the provisions of this CoP, the LPG supplier shall verify that the LPG hazardous substance location<sup>4</sup> has a current location test certificate issued by an approved test certifier in accordance with regulation 81 of the Hazardous Substances (Classes 1 to 5 Controls) Regulations, or has a valid Compliance Plaque<sup>5</sup>.

LPG delivery may then occur as in Section 4.3.

### **4.2 Within 60 days of the first LPG Delivery under the provisions of this CoP**

The LPG Supplier shall:

- establish the LPG location meets minimum standards in accordance with 'LPG Cylinder Location Compliance-Validation' items listed in Appendix B by receiving a completed and signed copy of Appendix B from the Authorized Signatory;
- fix to the location a unique numbered Compliance Plaque<sup>6</sup> confirming CoP compliance and an expiry date. Plaques shall be fixed in a permanent and prominent location, such as near the regulator.

LPG delivery may then continue as in Section 4.3

### **4.3 LPG Delivery & Ongoing Compliance, under the provisions of this CoP**

For each LPG delivery, the Trained LPG Delivery Operator shall:

- check CoP compliance plaque<sup>7</sup> is within its expiry date; and
- be satisfied the LPG location continues to meet the minimum standards in accordance with the 'LPG Location Compliance Guide' items (i) to (vi) listed in Appendix A.

LPG delivery may then occur in accordance with existing LPG Supplier procedures for supply of exchange cylinders, or, for in-situ filling, in accordance with LPG Association Approved Code of Practice 'In-Situ filling of LPG Cylinders', HSNOCOP 38.

In the event of non compliance, LPG shall not be delivered.

---

<sup>4</sup> By sighting the original Location Test Certificate and/or by reference to the ERMA

<sup>5</sup> Refer Section 5 for example

<sup>6</sup> Refer Section 5 for example

<sup>7</sup> Alternatively a current Location Test Certificate is acceptable

## 5. Renewal of Compliance Plaque

To enable LPG deliveries to continue, on or before the expiry date of each Compliance Plaque the LPG Supplier is required to complete and sign an 'LPG Cylinder Location 'Compliance-Validation' (Appendix B) confirming on-going compliance with the minimum standards.

Evidence of a signed LPG Cylinder Location 'Compliance-Validation' is required before:

- extending the expiry date; or
- fitting a new Compliance plaque with an extended expiry date.

Compliance Plaques shall have an expiry date no greater than 36 months from the date of the 'LPG Cylinder Location Compliance-Validation' inspection (Appendix B).

A signed 'LPG Cylinder Location Compliance-Validation' form (Appendix B) shall be held on file by the LPG Supplier and available for inspection.



## APPENDIX A

### ‘LPG Location Compliance Guide’ For Trained LPG Delivery Operator In accordance with HSNOCOP 50

<b>HSNO Compliance Items</b>	
i	Total quantity of LPG in cylinders is between 100 and 300kg
ii	Compliance plaque is within its expiry date; or A signed Appendix B ‘LPG Cylinder Compliance-Validation’ establishes a new expiry date for the Compliance plaque; or A current location test certificate is available for the site.
iii	<ul style="list-style-type: none"> <li>a) No apparent change to the environment around cylinder location such as new:               <ul style="list-style-type: none"> <li>• sealed drains or water traps</li> <li>• openings to buildings</li> <li>• electrical equipment/ignition sources (e.g. heat pump, pool pump)</li> </ul> </li> <li>b) an increase in the quantity of LPG</li> <li>c) a change from exchange cylinders to in-situ fill.</li> </ul>
iv	If there is any wall within 2 metres of the cylinders, the wall has not been changed and not damaged.
v	Security: The LPG cylinders at the location continue to be secured, that is: <ul style="list-style-type: none"> <li>• the site has a fenced perimeter, or</li> <li>• the cylinders are located in a cage, or</li> <li>• a tool is required to disconnect the cylinders, or</li> <li>• there is a security arrangement that is at least equivalent to the above.</li> </ul>
vi	Signage: Where the quantity of LPG is > 250 kg, emergency instructions and product identification signage exists and remains legible
<b>Supplementary Items</b>	
vii	Cylinders are: <ul style="list-style-type: none"> <li>• located on a stable non combustible base raised above the surrounding area that shall shed water; and</li> <li>• restrained (chained) against earthquake movement.</li> </ul>
viii	Installation Condition: <ul style="list-style-type: none"> <li>• Flexible pigtails are serviceable, i.e. free from cuts, abrasions or other significant damage or deterioration.</li> <li>• Fittings are free of significant corrosion or damage.</li> <li>• The LPG area is free of debris, vegetation or any other combustible materials.</li> </ul>

**Note**

Appendix A content may be incorporated into LPG supplier’s own documentation

# APPENDIX B

## LPG Cylinder Location ‘Compliance-Validation’ In accordance with HSNOCOP 50

Item		Compliant Yes <input checked="" type="checkbox"/> No <input checked="" type="checkbox"/> n/a
1	Total quantity of LPG in cylinders is between 100kg to 300kg	
2	The environment around cylinder location appears unchanged.	
3	Hazardous Atmosphere & Location	
3.1	Cylinders are installed on a stable non combustibile base raised above the surrounding area and shall shed water	
3.2	Restrained (chained) against earthquake movement	
3.3	If there is any wall within 2 metres of the cylinders does the fire resisting material remain unchanged and undamaged?	
3.4	For <b>Exchange</b> cylinders: <ul style="list-style-type: none"> <li>No openings to drains or buildings within 2metres horizontally from cylinders and 150mm above the cylinders</li> <li>No electrical equipment/ignition sources within Fig F1 distances.</li> </ul>	
3.5	For <b>In-Situ fill</b> cylinders: <ul style="list-style-type: none"> <li>No openings to drains or buildings within 2 metres horizontally from cylinders and 500mm above the cylinders</li> <li>No electrical equipment/ignition sources within Fig F2 distances.</li> </ul>	
4	Signage: Signage with emergency instructions and product identification is provided and legible on all sites with >250 kg storage.	
5	Security: The LPG cylinders at the location remain secured or have enhanced security.	
6	Handling of LPG: No handling of LPG occurs on site other than by the LPG Supplier’s Trained LPG Delivery Operator.	
7	Fire Extinguisher: If the location is a place of work, at least one 2 kg dry chemical extinguisher is provided and is located within 30m of the LPG cylinders.	

Location (Street address): .....

Unique Plaque Number: .....Plaque Expiry Date: .....

On the day of inspection the LPG location at the above address complied with the above listed requirements:

Signed:

Inspection Date:

Authorized Signatory Name:

Title:

LPG Supplier:

# Hazardous Atmosphere (and No Source of Ignition) Zones

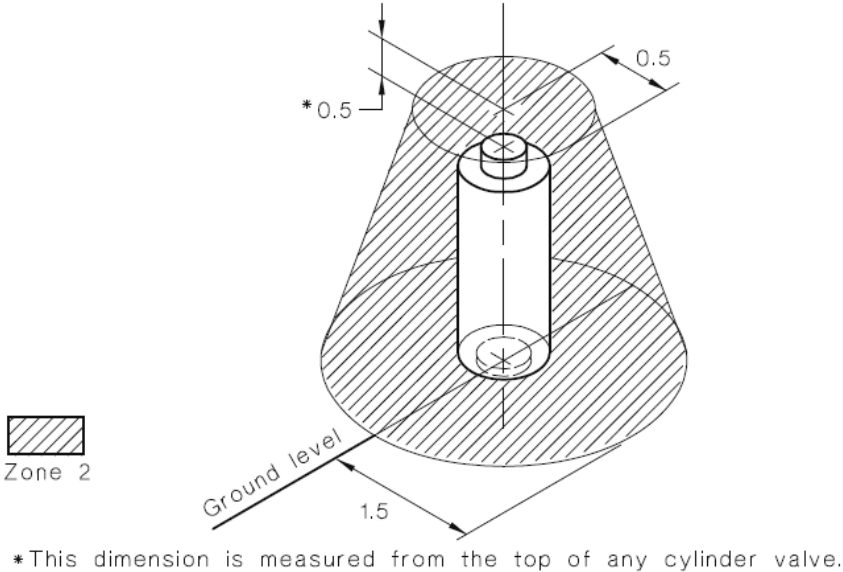

DIMENSIONS IN METRES  
FIGURE F1 EXCHANGE CYLINDER

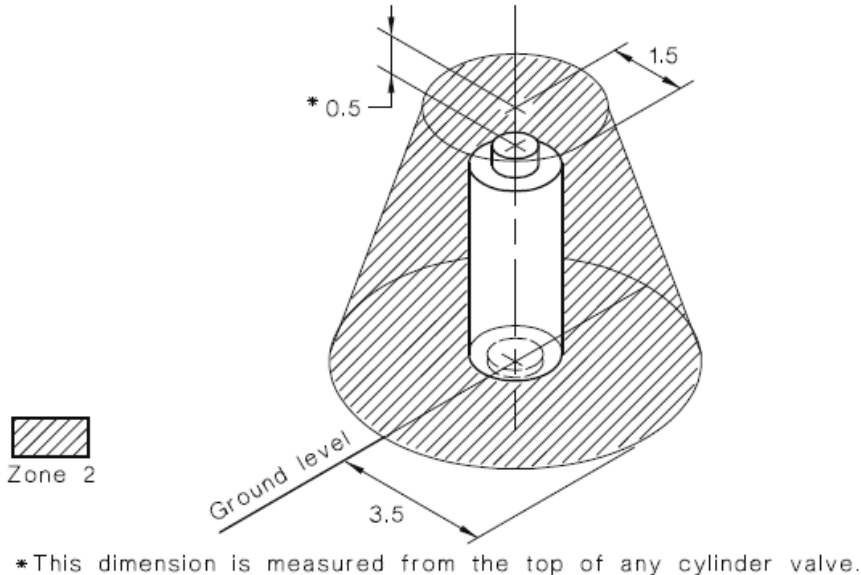

DIMENSIONS IN METRES  
FIGURE F2 IN-SITU FILL CYLINDER